

HygroClip2 ADVANCED

Humidity Temperature Probes



HygroClip2 ADVANCED	rotronic
E-M-HC2A-V1_7.docx	Manual

Table of contents

1	Overview.....	3
1.1	Hardware and software compatibility	3
2	Models	4
3	General description	8
3.1	Power supply.....	12
3.2	Measured parameters	12
3.3	Calculated parameters	12
3.4	Analog output signals.....	12
3.5	Digital interface	13
3.6	Communication protocol	13
3.7	Connector	14
3.8	Filter and probes overview matrix	15
3.9	Sensor protection (dust filter)	16
4	User configurable settings and functions	18
4.1	Function overview	18
4.2	Factory default settings	20
5	Mechanical installation	21
6	Electrical installation.....	22
6.1	General connection information	22
6.2	Signal cable information.....	22
6.3	Analog signal wiring	23
6.4	Digital signal wiring	23
6.5	Grounding	23
7	Operation.....	24
7.1	Minimum load requirements for the probe voltage outputs	24
7.2	Connectivity examples for stand-alone probes.....	25
7.3	Hand-held probes used with an indicator	26
8	Maintenance.....	27
8.1	Cleaning or replacing the dust filter.....	27
8.2	Periodic calibration check	27
8.3	Validation of the output signals transmission	27
9	Firmware updates	28
10	Technical data.....	29
11	Accessories and parts	32
12	Supporting documents	32
13	Document releases.....	33

HygroClip2 ADVANCED	rotronic
E-M-HC2A-V1_7.docx	Manual

Applicability:

This manual applies to all HC2A probes with firmware version 1.x. Changes to the last digit of the version number reflect minor firmware changes that do not affect the manner in which the probe should be operated.

1 Overview

The HC2A series are digital humidity-temperature probes based on the AirChip3000 technology. These probes feature a UART serial interface and two 0...1 V linear analog output signals.

The HC2A probes are designed for use with the HygroClip2 generation of ROTRONIC humidity-temperature instruments: transmitters, data loggers, hand-helds, etc.

The HC2A probes can also be used as a stand-alone device using either the analog output signals or the probe digital interface. Connectors, cables and digital interface adapters are available to this purpose. Digital integration with OEM applications is facilitated by the probe communication protocol options.

The HC2A probes offer the following user functions:

- User configurable settings
- Calculation of the dew or frost point
- Humidity temperature calibration and adjustment
- Simulator mode
- Data recording

The ability for the user to easily update the AirChip3000 firmware means that the HC2A probes can be kept up-to-date regarding any future functionality improvement.

Available in different configurations, the HC2A probe series is designed to meet the requirements of a large number of applications and environments.

1.1 *Hardware and software compatibility*

The HC2A probes are compatible only with the AirChip3000 generation of ROTRONIC humidity-temperature instruments.

Configuration of the HC2A probes and access to the probe functions requires a PC with the ROTRONIC HW4 software version 3.7 or higher or the ROTRONIC software HW5 or connection to a compatible instrument from ROTRONIC.

HygroClip2 ADVANCED	rotronic
E-M-HC2A-V1_7.docx	Manual

2 Models

In the following tables, we have indicated the type of instrument primarily used with each probe model. The following should also be noted:

- The HC2A probes can be directly connected to a PC or to an Ethernet network using one of the available digital interface adapters (see separate document **E-M-HC2-accessories**).
- The HC2A Probes can also be used as a standalone device with two analog output signals. Different connectors are available to this purpose (see separate document **E-M-HC2-accessories**).

Regardless of the probe model, the analog outputs signals are always scaled in the same way by the factory (0...1 V = 0...100 %RH and 0...1 V = -40...60 °C). The user is responsible for reconfiguring the probe analog outputs (requires the ROTRONIC HW4 respective ROTRONIC HW5 software) and for providing power to the probe.

Climate measurement	
<i>For use with indicators, data loggers and transmitters, with or without an extension cable</i>	
HC2A-S	Accuracy: ± 0.8 %RH, ± 0.1 K at 10...30 °C Humidity measuring range: 0...100 %RH Temperature limits: -50...100 °C (-58...212 °F) Diameter: 15 mm (0.6") Length: 108 mm (3.3") Housing material: Polycarbonate, black Standard dust filter: Polyethylene, 40 μ m Sensor: HYGROMER® HT-1 Weight: 17 g (0.6 oz)
HC2A-S3	Accuracy: ± 0.8 %RH, ± 0.1 K at 10...30 °C Humidity measuring range: 0...100 %RH Temperature limits: -50...100 °C (-58...212 °F) Diameter: 15 mm (0.6") Length: 108 mm (3.3") Housing material: Polycarbonate, white Standard dust filter: Polyethylene, 40 μ m Sensor: HYGROMER® HT-1 Weight: 17 g (0.6 oz)
HC2A-S3A	Accuracy: ± 0.8 %RH, ± 0.1 K at 10...30 °C Humidity measuring range: 0...100 %RH Temperature limits: -50...80 °C (-58...176 °F) Diameter: 15 mm (0.6") Length: 108 mm (3.3") Housing material: Polycarbonate, white Standard dust filter: Wiremesh filter, 10 μ m, DIN 1.4401 Sensor: HYGROMER® HM1-SK Weight: 17 g (0.6 oz)
HC2A-SH	Accuracy: ± 0.5 %RH, ± 0.1 K at 10...30 °C Humidity measuring range: 0...100 %RH Temperature limits: -50...100 °C (-58...212 °F) Diameter: 15 mm (0.6") Length: 108 mm (3.3") Housing material: Polycarbonate, black Standard dust filter: Polyethylene, 40 μ m Sensor: HYGROMER® HT-1 Weight: 17 g (0.6 oz)

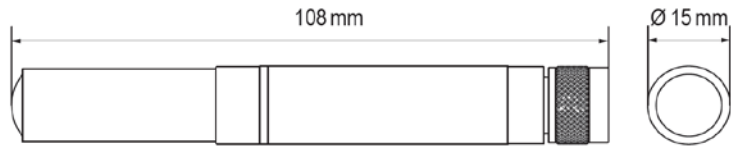
<p>HC2A-S3H</p>	<p>Accuracy: $\pm 0.5\%RH, \pm 0.1\text{ K at } 10...30\text{ }^\circ\text{C}$ Humidity measuring range: 0...100 %RH Temperature limits: -50...100 °C (-58...212 °F) Diameter: 15 mm (0.6") Length: 108 mm (3.3") Housing material: Polycarbonate, white Standard dust filter: Polyethylene, 40 µm Sensor: HYGROMER® HT-1 Weight: 17 g (0.6 oz)</p>
<p>HC2A-SG</p>	<p>Accuracy: $\pm 0.8\%RH, \pm 0.1\text{ K at } 10...30\text{ }^\circ\text{C}$ Humidity measuring range: 0...100 %RH Temperature limits: -50...100 °C (-58...212 °F) Diameter: 15 mm (0.6") Length: 108 mm (3.3") Housing material: Polycarbonate, black Standard dust filter: Polyethylene, 40 µm Sensor: HYGROMER® HT-1 Weight: 17 g (0.6 oz)</p>
<p>HC2A-S-HH</p>	<p>Accuracy: $\pm 1.0\%RH, \pm 0.1\text{ K at } 10...30\text{ }^\circ\text{C}$ Humidity measuring range: 0...90 %RH Temperature limits: 0...60 °C (32...140 °F) Diameter: 15 mm (0.6") Length: 108 mm (3.3") Housing material: Polycarbonate, black Standard dust filter: None Sensor: HYGROMER® HH-1 Weight: 17 g (0.6 oz)</p>
	

Climate measurement

For use with indicators, data loggers and transmitters, with or without an extension cable

HC2A-SM	Accuracy:	± 0.8 %RH, ± 0.1 K at 10...30 °C
	Humidity measuring range:	0...100 %RH
	Temperature limits:	-50...100 °C (-58...212 °F)
	Diameter:	15 mm (0.6")
	Length:	109 mm (3.3")
	Housing material:	Stainless steel, DIN 1.4301
	Standard dust filter:	Wiremesh filter, 10 μ m, DIN 1.4401
	Sensor:	HYGROMER® HT-1
Weight:	50 g (1.76 oz)	

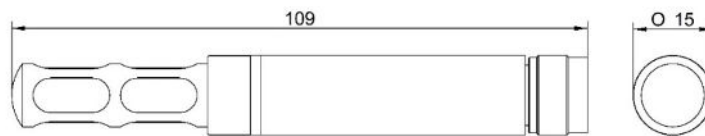

Process measurement

For use with transmitters and data loggers

HC2A-IC102 HC2A-IC105	Accuracy:	± 0.8 %RH, ± 0.1 K at 10...30 °C
	Humidity measuring range:	0...100 %RH
	Temperature limits at sensor:	-100...190 °C / 200 °C ¹ (-148...374 / 392 °F)
	Diameter barrel:	15 mm (0.6")
	Length (probe head):	144 mm (5.7")
	Cable length:	2 m (6.5 ft) / 5 m (16.4 ft)
	Housing material:	PPS
	Standard filter:	None, must be ordered separately
Sensor:	HYGROMER® HT-1	
Weight:	230 g (8.1 oz), 2 m cable / 470 g (16.6 oz), 5 m cable	

¹ The peak load at 200 °C is 100 h. See the sensor data sheet for detailed information on the pollution loads for the sensor.

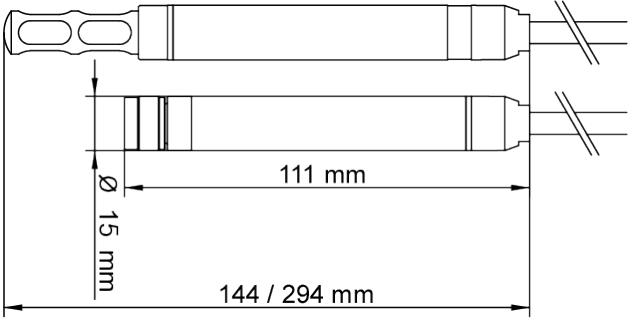
HC2A-IC302	<p>Accuracy: $\pm 0.8\% \text{RH}$, $\pm 0.1 \text{ K}$ at $10 \dots 30 \text{ }^\circ\text{C}$</p> <p>Humidity measuring range: $0 \dots 100\% \text{RH}$</p> <p>Temperature limits at sensor: $-100 \dots 190 \text{ }^\circ\text{C}$ / $200 \text{ }^\circ\text{C}^1$ ($-148 \dots 374$ / $392 \text{ }^\circ\text{F}$)</p> <p>Diameter barrel: 15 mm ($0.6''$)</p> <p>Length (probe head): 294 mm ($11.6''$)</p> <p>Cable length: 2 m (6.5 ft)</p> <p>Housing material: PPS</p> <p>Standard filter: None, must be ordered separately</p> <p>Sensor: HYGROMER® HT-1</p> <p>Weight: 260 g (9.2 oz), 2 m cable</p>
	

¹ The peak load at $200 \text{ }^\circ\text{C}$ is 100 h. See the sensor data sheet for detailed information on the pollution loads for the sensor.

Process measurement	
<i>For use with transmitters and data loggers</i>	
HC2A-IC402-A	<p>Accuracy: $\pm 0.8\% \text{RH}, \pm 0.1 \text{ K}$ at 10...30 °C</p> <p>Humidity measuring range: 0...100 %RH</p> <p>Temperature limits at sensor: -100...190 °C / 200 °C¹ (-148...374 / 392 °F)</p> <p>Diameter barrel: 15 / 25 mm (0.6" / 1.0")</p> <p>Length (probe head): 428 mm (16.9")</p> <p>Cable length: 2 m (6.5 ft)</p> <p>Housing material: PPS</p> <p>Standard filter: None, must be ordered separately</p> <p>Sensor: HYGROMER® HT-1</p> <p>Weight: 320 g (11.3 oz), 2 m cable</p>
HC2A-IC702-A	<p>Accuracy: $\pm 0.8\% \text{RH}, \pm 0.1 \text{ K}$ at 10...30 °C</p> <p>Humidity measuring range: 0...100 %RH</p> <p>Temperature limits at sensor: -100...190 °C / 200 °C¹ (-148...374 / 392 °F)</p> <p>Diameter barrel: 15 / 25 mm (0.6" / 1.0")</p> <p>Length (probe head): 728 mm (28.6")</p> <p>Cable length: 2 m (6.5 ft)</p> <p>Housing material: PPS</p> <p>Standard filter: None, must be ordered separately</p> <p>Sensor: HYGROMER® HT-1</p> <p>Weight: 380 g (13.4 oz), 2 m cable</p>

¹ The peak load at 200 °C is 100 h. See the sensor data sheet for detailed information on the pollution loads for the sensor.

Process measurement	
<i>For use with transmitters and data loggers</i>	
HC2A-IM102-M	<p>Accuracy: $\pm 0.8\% \text{RH}$, $\pm 0.1 \text{ K}$ at $10 \dots 30 \text{ }^\circ\text{C}$</p> <p>Humidity measuring range: $0 \dots 100\% \text{RH}$</p> <p>Temperature limits at sensor: $-100 \dots 190 \text{ }^\circ\text{C}$ / $200 \text{ }^\circ\text{C}^1$ ($-148 \dots 374$ / $392 \text{ }^\circ\text{F}$)</p> <p>Diameter barrel: 15 mm ($0.6''$)</p> <p>Length (probe head): 130 mm ($4.7''$)</p> <p>Cable length: 2 m (6.5 ft)</p> <p>Housing material: PEEK</p> <p>Standard filter: None, must be ordered separately</p> <p>Sensor: HYGROMER® HT-1</p> <p>Weight: 230 g (8.1 oz), 2 m cable</p>
HC2A-IM302-M HC2A-IM305-M	<p>Accuracy: $\pm 0.8\% \text{RH}$, $\pm 0.1 \text{ K}$ at $10 \dots 30 \text{ }^\circ\text{C}$</p> <p>Humidity measuring range: $0 \dots 100\% \text{RH}$</p> <p>Temperature limits at sensor: $-100 \dots 190 \text{ }^\circ\text{C}$ / $200 \text{ }^\circ\text{C}^1$ ($-148 \dots 374$ / $392 \text{ }^\circ\text{F}$)</p> <p>Diameter barrel: 15 mm ($0.6''$)</p> <p>Length (probe head): 280 mm ($11.0''$)</p> <p>Cable length: 2 m (6.5 ft) 5 m (16.4 ft)</p> <p>Housing material: PEEK</p> <p>Standard filter: None, must be ordered separately</p> <p>Sensor: HYGROMER® HT-1</p> <p>Weight: 260 g (9.17 oz), 2 m cable 500 g (17.6 oz), 5 m cable</p>
<p>The diagram shows two views of the probe. The top view shows the full probe with a cable. The bottom view shows the probe head with dimensions: a diameter of 15 mm, a probe head length of 97 mm, and a total length of 130 mm for the shorter model and 280 mm for the longer model.</p>	

¹ The peak load at $200 \text{ }^\circ\text{C}$ is 100 h . See the sensor data sheet for detailed information on the pollution loads for the sensor.

Measurement in compressed air conduits and vessels
For use with transmitters and data loggers

HC2A-IE02-G	Accuracy: $\pm 0.8\% \text{RH}$, $\pm 0.1 \text{ K}$ at $10 \dots 30 \text{ }^\circ\text{C}$ Humidity measuring range: $0 \dots 100\% \text{RH}$ Temperature limits at sensor: $-100 \dots 190 \text{ }^\circ\text{C}$ / $200 \text{ }^\circ\text{C}^1$ ² ($-148 \dots 374$ / $392 \text{ }^\circ\text{F}$) Thread: G1/2" Recommended torque: 70 Nm Pressure resistant: 100 bar / 1450 PSI Length (probe head): 148 mm (5.8") Cable length: 2 m (6.5 ft) Housing material: Stainless steel, DIN 1.4301 Standard filter: None, must be ordered separately Sensor: HYGROMER® HT-1 Weight: 290 g / (10.2 oz), 2 m cable
HC2A-IE02-NPT	Accuracy: $\pm 0.8\% \text{RH}$, $\pm 0.1 \text{ K}$ at $10 \dots 30 \text{ }^\circ\text{C}$ Humidity measuring range: $0 \dots 100\% \text{RH}$ Temperature limits at sensor: $-100 \dots 190 \text{ }^\circ\text{C}$ / $200 \text{ }^\circ\text{C}^1$ ² ($-148 \dots 374$ / $392 \text{ }^\circ\text{F}$) Thread: NPT 1/2" Recommended torque: 70 Nm Pressure resistant: 100 bar / 1450 PSI Length (probe head): 148 mm (5.8") Cable length: 2 m (6.5 ft) Housing material: Stainless steel, DIN 1.4301 Standard filter: None, must be ordered separately Sensor: HYGROMER® HT-1 Weight: 290 g / (10.2 oz), 2 m cable

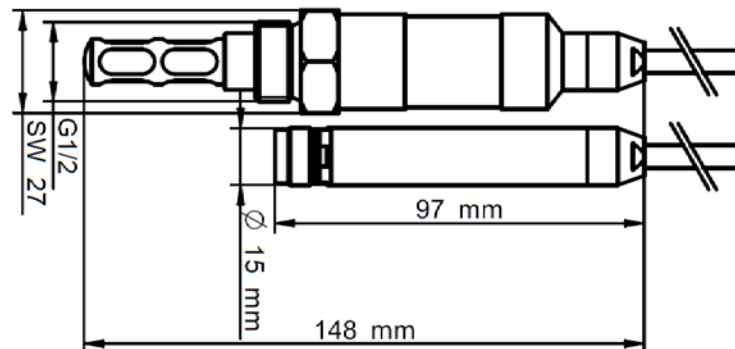

¹ The peak load at $200 \text{ }^\circ\text{C}$ is 100 h. See the sensor data sheet for detailed information on the pollution loads for the sensor.

² The sealing ring withstands only $-40 \dots 100 \text{ }^\circ\text{C}$

HygroClip2 ADVANCED	rotronic
E-M-HC2A-V1_7.docx	Manual

3 General description

3.1 Power supply

When a voltage source of 3.3...5 VDC is not available, the probe should be used together with a voltage adapter (see separate document **E-M-HC2-accessories**) so as to provide 3.3...5 VDC to the probe. Use of a voltage adapter allows powering the probe from a voltage source of 5 to 24 VDC or 5 to 16 VAC.

The HC2A probes are polarity protected by a keyed connector. There is no electrical polarity protection.

3.2 Measured parameters

The HC2A probe measures relative humidity with a ROTRONIC HYGROMER® HT-1 capacitive sensor and temperature with a Pt100 RTD.

3.3 Calculated parameters

Using the ROTRONIC HW4 software, the HC2A probe can be configured by the user to calculate either the dew point or the frost point.

3.4 Analog output signals

The HC2A probe features two 0...1 V linear analog output signals. The default factory settings are as follows:

Output 1: 0...1 V (humidity) = 0...100 %RH

Output 2: 0...1 V (temperature) = -40...60°C

Using the ROTRONIC HW4 / HW5 software any output signal can be made to correspond one of the following:

- Relative humidity
- Temperature
- Dew or frost point

The scale of each analog output can be set within the numerical limits of -999.99 and 9999.99. If so desired, any output can also be disabled (no signal).

The D/A converters used to generate the analog output signals feature a 16-bit resolution. The 0...1 V analog output signals exhibit a small positive offset of 10 mV or less at 0 V.

Minimum load requirements apply to the external device or circuit connected to the probe voltage outputs. These requirements are defined in the "Operation" chapter.

HygroClip2 ADVANCED	rotronic
E-M-HC2A-V1_7.docx	Manual

3.5 *Digital interface*

The HC2A probe features a UART interface (Universal Asynchronous Receiver Transmitter) that allows two-way communication with the probe. For connecting the HC2A probe to a PC, use a digital adapter cable AC3001 (see document **E-M-HC2-accessories**). The probe can also be indirectly connected to a PC using an instrument from the ROTRONIC program.

3.5.1 HW4 software (version 3.7.0 or higher) allows full access to the following:

- Measurement data (humidity and temperature) and calculated parameter (dew or frost point)
- Probe information: name, RS-485 address, humidity sensor status, etc.
- Probe alarm functions
- Probe data logging function
- Probe calibration and probe adjustment functions
- Probe configuration
- Firmware update of HygroClip2 probes

3.5.2 HW5 software allows full access to the following:

- Measurement data (humidity and temperature) and calculated parameter (dew or frost point)
- Probe information: name, RS-485 address, humidity sensor status, etc.
- Probe data logging function (Monitoring only for water activity measurement HW5-AW-CODE)
- Probe calibration and probe adjustment functions
- Probe configuration
- Firmware update of HygroClip2 probes

3.6 *Communication protocol*

The probe measurement data can be read without having to use the ROTRONIC HW4 / HW5 software. The HC2A probe offers the following communication protocol options (ASCII) which can be selected by connecting the probe to a PC running the ROTRONIC HW4 / HW5 software:

- **RO-ASCII:** this is the standard (default) communication protocol used by all AirChip 3000 devices and by the HW4 / HW5 software. In principle, this protocol supports all of the AirChip 3000 functions but some of the functions require a certain amount of computations to be carried out by an external device such as a PC.
- **Custom:** this communication protocol can be used to provide compatibility of the HC2A probe with an existing communication system. The Custom communication protocol is limited to reading measurement data from the HC2A probe. Functions such as device configuration, humidity and temperature adjustment, etc. are not supported. The Custom protocol is applicable to all AirChip 3000 devices with a digital interface and allows RS-485 networking

- **I2C:** The I2C protocol available with the HC2A probe does not allow the networking of devices and is limited to a one way communication where the HC2A probe automatically sends data during each refresh interval to an external device with I2C input.

When using either the RO-ASCII or the Custom protocol, the HC2A probe can be set to send data automatically after each refresh cycle without requiring a data request. When this mode is enabled, the receiving device must be listening at all times in order to get the measurement data.

For details, see document **E-M-AC3000-CP**

3.7 Connector

All standard probe models of the HC2A series use the same keyed connector (male). The connector is located either directly on the probe body or at the end of a cable. The probe connector is secured to the matching female connector with a threaded collar.

Pin-out diagram (7-pin male – looking at probe)

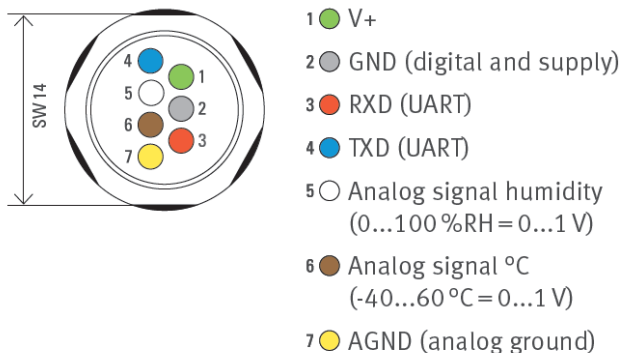

3.8 Filter and probes overview matrix

	Temperature range	Probes											
		-50...100°C							-40...85°C	-100...200°C			
		HC2A-S	HC2A-S3	HC2A-S3A	HC2A-SH	HC2A-S3H	HC2A-S-HH	HC2A-SM	XD33A-S3X	HC2A-ICxxx	HC2A-ICxxx-A	HC2A-IMxxx-IM	HC2A-IExxx
Carrier	-50...100°C	SPA-PCB			X					X			
		SPA-PCW			X					X			
	-100...200°C	SPA-SS			X			X		X		X	
Filter&Carrier	-50...100°C	SPA-PCB-PE			X					X			
		SPA-PCB-PTFE			X					X			
		SPA-PCB-WM			X					X			
		SPA-PCW-PE			X					X			
		SPA-PCW-PTFE			X					X			
		SPA-PCW-WM			X					X			
		SPA-SS-PE			X			X		X			
	SPA-PE			X			X		X				
	-100...200°C	SPA-SS-PTFE			X			X		X		X	
		SPA-SS-WM			X			X		X		X	
SPA-SSS				X			X		X		X		
SPA-WM				X			X		X		X		
SPA-PTFE				X			X		X		X		

Attention! The area of application depends on the component with the most restricted temperature range.

3.9 Sensor protection (dust filter)

Most probes of the HC2A series are supplied with a filter to protect the sensors against dust particles and high air velocity. Following filters and carriers are available:

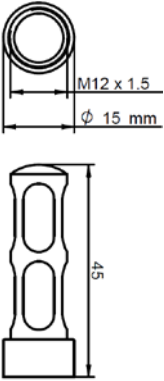
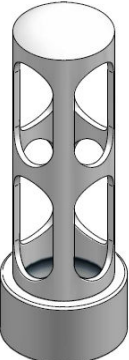
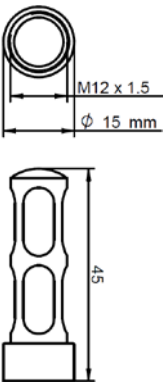
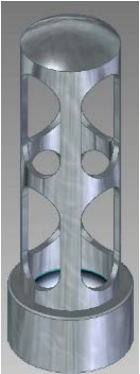
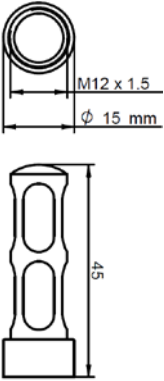
Filter carrier				
Order code	Picture	Drawing	Material	Temperature range
SPA-PCB			Polycarbonate, black	-50...100 °C (-58...212 °F)
SPA-PCW			Polycarbonate, white	-50...100 °C (-58...212 °F)
SPA-SS			Stainless steel, 1.4301	-100...200 °C (-148...392 °F)

	Carrier only	Wire mesh filter	PE filter	PTFE filter	Stainless steel
Filter					
Material	PC / 1.4301	1.4401	Polyethylene	PTFE	1.4404
Pore size	-	10 µm	40-50 µm	10 µm	25 µm
Temperature range	-50...100 °C	-100...200 °C (-148...392 °F)	-50...100 °C (-58...212 °F)	-80...200 °C (-112...392 °F)	-100...200 °C (-148...392 °F)
Response time %RH³	12 s	12 s	15 s	18 s	15 s
Response time °C⁴	80 s	180 s	180 s	170 s	-
Response time °C⁵	120 s	190 s	210 s	210 s	200 s
Waterproof (dipping 50mm)	No	No	Yes	Yes	No
Max. wind speed	5 m/s	50 m/s	50 m/s	50 m/s	70 m/s
Suitable for fine dust	No	No	>10 µm	Yes	No
General information	Fast response time	High temperature, fast response time, fast drying, mechanically robust	Standard filter	High chemical resistance, fine dust resistant, high temperature	High wind speed, abrasive environment, high mechanical protection
Application	Sterilization, H ₂ O ₂ , handheld devices	Meteo, agriculture, climatic chambers, storage rooms, cheese cellar	HVAC, office, storage rooms, laboratory, clean rooms	Cleanrooms, medical, injection chamber, meal manufacturing	HVAC with high wind speed, industrial applications

³ T63: 100 %RH → 30 %RH⁴ PC carrier: 70 °C → 23 °C⁵ Stainless steel carrier: 70 °C → 23 °C

HygroClip2 ADVANCED	rotronic
E-M-HC2A-V1_7.docx	Manual

4 User configurable settings and functions

The HC2A probe ships configured as per the factory defaults:

- Users who intend to use the probe as a stand-alone analog device can use the probe as any conventional humidity and temperature probe. A connecting cable with active electronics may be required to power the probe. Most such users will never have to use the probe configurable settings and functions.
- Users who purchased a probe for use with another ROTRONIC instrument can also use the probe right away and do not necessarily have to use the probe configurable settings and functions
- Users that intend to use the probe as a stand-alone digital device typically need to use a connecting cable with active electronics and generally need to configure either the probe or the PC

Making use of the probe configurable settings and functions is entirely up to the user and the appropriate settings depend on the user application. We have provided below a short description of the probe functions and also indicated the factory default settings.

4.1 Function overview

MEASUREMENT ACCURACY AND RELIABILITY	
AirChip3000 Functions	Description
▶ Humidity / temperature adjustment	<ul style="list-style-type: none"> ○ 1-point or multi-point humidity calibration or adjustment ○ 1-point or 2-point temperature calibration or adjustment ○ Generate a time stamp for calibrations and adjustments ○ Retain and view last adjustment date and adjustment values ○ Generate calibration and adjustment protocols
▶ Data recording	<p>The data recording function differs from a true data logging function in the sense that the AirChip3000 does not time stamp the data. This data recording function can be used to investigate events such as a sensor malfunction as well as to retrieve data that would otherwise be lost.</p> <ul style="list-style-type: none"> ○ Start or stop data recording - up to 2000 value pairs (%RH and temperature). Starting a recording session erases all previously recorded data. ○ The recording mode and log interval can be specified. ○ When the probe is powered off, the recording session is paused but not ended. As long as the recording session has not been ended, the probe automatically resumes recording data when powered up again.

HygroClip2 ADVANCED	rotronic
E-M-HC2A-V1_7.docx	Manual

	<ul style="list-style-type: none"> ○ The recorded data can be downloaded to a PC with the HW5 software, time stamped and viewed.
--	---

MEASUREMENT LOOP VALIDATION	
AirChip3000 Functions	Description
▶ Simulator mode	Used to make the probe generate fixed values for the humidity, temperature and calculated parameter. Can be configured, enabled or disabled.

SAFEGUARDS	
AirChip3000 Functions	Description
▶ Device write protection	Used to protect the probe with a password to prevent unauthorized digital access by a digital user. Can be configured, enabled or disabled

PROCESS PROTECTION / PROTECTION OF OTHER DEVICES	
AirChip3000 Functions	Description
▶ Out-of-limit value alarm	Used to specify the normal range for humidity, temperature and the calculated parameter depending on the user application. Can be configured, enabled or disabled. Out-of-limit values trigger a digital alarm

HygroClip2 ADVANCED	rotronic
E-M-HC2A-V1_7.docx	Manual

4.2 Factory default settings

Configurable Settings	Factory default
Unit system (Metric or English)	Metric
Psychrometric calculation	None
Output 1 parameter, scale and unit	Humidity: 0...100%RH
Output 2 parameter, scale and unit	Temperature: -40...60 °C
Communication protocol	RO-ASCII
RS-485 address	0
Device name	HC2A

Functions	Factory default
Humidity / temperature adjustment	Enabling / Disabling only by HW4 / HW5 user rights possible
Device write protection	Disabled
Out-of-limit value digital alarm	Disabled
Data recording	Disabled
Simulator mode	Disabled

For a detailed description of all AirChip3000 / probe main functions see document **E-T-AC3000-DF-V1**.

Instructions regarding the configuration of the probe and access to its functions are provided in the following manuals:

- **E-M-HW4v3-Main**
- **E-M-HW4v3-F2-001**
- **E-M-HW4v3-DR-001**
- **E-M-HW4v3-A2-001**
- **E-M-AC3000-CP**
- [Online manual HW5](#)

5 Mechanical installation

For best results, please observe the following guidelines:

- Install the probe at a location where humidity, temperature and pressure conditions are representative of the environment or process to be measured. Avoid the following: (a) Close proximity of the probe to a heating element, a cooling coil, a cold or hot wall, direct exposure to sun rays, etc. (b) Close proximity of the probe to a steam injector, humidifier, direct exposure to precipitation, etc. (c) Unstable pressure conditions resulting from excessive air turbulence.
- When installing the probe on a wall, do not place the probe right above a heat producing device of instrument such as a transmitter or an Ethernet adapter (warm air tends to rise).
- If possible, choose a location that provides good air movement at the probe: air velocity of at least 1 meter/second (200 ft/ minute) facilitates adaptation of the probe to changing temperature.
- When installing the probe through a wall, immerse as much of the probe as possible in the environment to be measured.

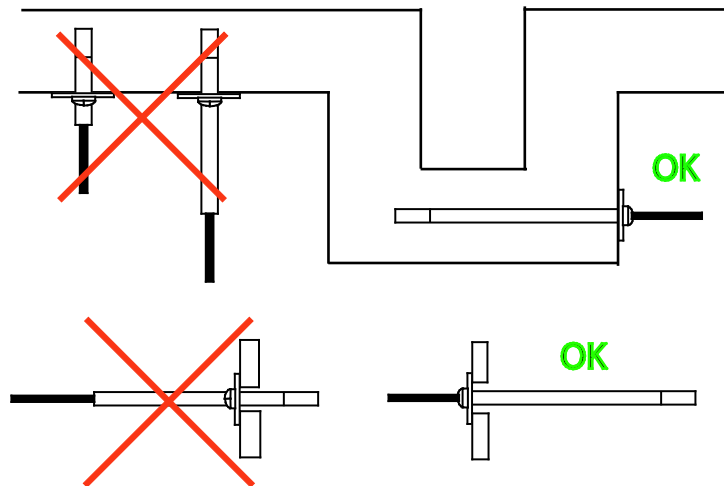

Position the probe so as to prevent the accumulation of condensation water at the level of the sensor leads. Install the probe so that the probe tip is looking downward. If this is not possible, install the probe horizontally.

Depending on the probe model, a probe holder (mounting flange with a compression fitting) can facilitate installation through a wall.

Future maintenance can be made easier by providing next to the probe a calibration access orifice. During maintenance, this permits the insertion of a reference probe (calibrator). The calibration access orifice should have the same size as the orifice used to install the probe and can be equipped with a probe holder.

HygroClip2 ADVANCED	rotronic
E-M-HC2A-V1_7.docx	Manual

6 Electrical installation

This section describes the general safety precautions for electric wiring.

6.1 General connection information

Heavy machinery and instrumentation should not share the same power supply wiring. If this cannot be avoided, noise filters and surge protectors should be used. Most UPS devices have those features already integrated.

6.2 Signal cable information

The following guidelines are derived from the European standard EN 50170 for the transmission of signals by copper wires. Note on installation planning: when determining the position of machinery and equipment, the rules given in EN 50170 should be followed with due regard to local circumstances.

Whenever the level of electromagnetic interference is expected to be high, both the instruments and signal cables should be placed as far away as possible from the source of interference.

In general, signal cables should be installed in bundles or channels / conduits, separate from other cables as indicated in the table below:

<ul style="list-style-type: none"> ○ Bus signals such as RS485 ○ Data signals for PCs, printers etc. ○ shielded analog inputs ○ unshielded direct current ($\leq 60V$) ○ shielded process signals ($\leq 25 V$) ○ unshielded alternate current ($\leq 25V$) ○ coaxial cables for CRT monitors 	in common bundles or channels / conduits
<ul style="list-style-type: none"> ○ direct current from 60 V to 400 V (unshielded) ○ alternate current from 25V to 400 V (unshielded) 	in separated bundles or channels / conduits, without minimum distance
<ul style="list-style-type: none"> ○ direct and alternate current $> 400 V$ (unshielded) ○ Telephone lines ○ lines leading into EX-rated areas 	in separated bundles or channels / conduits, without minimum distance

HygroClip2 ADVANCED	rotronic
E-M-HC2A-V1_7.docx	Manual

6.3 *Analog signal wiring*

Preferably use a shielded cable to connect the analog outputs of the HC2A to other devices. The maximum cable length is determined by the maximum error that the user will accept. This can be calculated as follows:

Error (V) = cable resistance x current through load

6.4 *Digital signal wiring*

Use one of the available connecting cables (see Accessories) to connect the UART digital interface of the HC2A probe to other devices. Without a signal booster, the maximum cable length should not exceed 5 m (16 ft).

6.5 *Grounding*

In the case of a fixed installation, ground the HC2A probe, especially if the electronics will be subjected to a low humidity environment (35 %RH or less). The power supply and digital ground (GND) and the analog ground (AGND) should be tied separately to a proper ground so as to avoid spikes in the analog signals.

7 Operation

The HC2A probes are compatible with a large number of indicators, data loggers and transmitters from ROTRONIC. Operating instructions are provided in each device manual. The HC2A probes can also be used as a conventional analog probe. See Accessories, supply voltage adapters, connectors and cables. Use the HW4 software to configure the probe as desired, complete the mechanical and electrical installation and power up the probe.

7.1 *Minimum load requirements for the probe voltage outputs*

In the situation where the external device uses an internal pull-up resistor the value of this resistor should meet the requirements shown below. It is also necessary to add a pull-down resistor R_L connected to ground in order to be able to read 100% of the range of the probe voltage output.

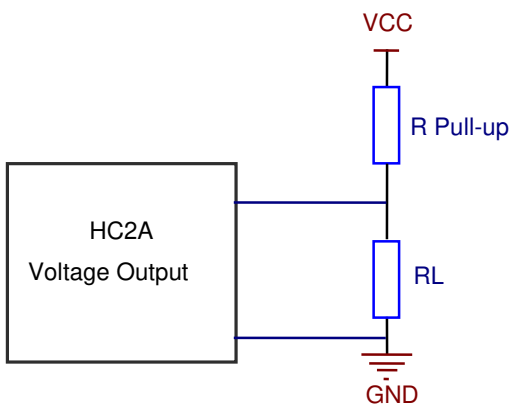

HC2A signal	VCC	R pull-up	RL
0...1V	3.3V	$\geq 250 \text{ k}\Omega$	1 k Ω
0...1V	5.0V	$\geq 400 \text{ k}\Omega$	1 k Ω
0...1V	10.0V	$\geq 1 \text{ M}\Omega$	1 k Ω

7.2 Connectivity examples for stand-alone probes

Stand-alone operation as a digital probe (PC or network)

The HC2A probes can be connected to a PC or to an Ethernet network with one of the available digital interface adapters (see Accessories). Probe configuration and full access to all probe functions requires a PC with the ROTRONIC HW4 software installed. When using the standard RO-ASCII protocol, access to some of the probe functions is also possible without HW4. For details, see document **E-M-AC3000-CP**.

Digital connection example: RS-485 network

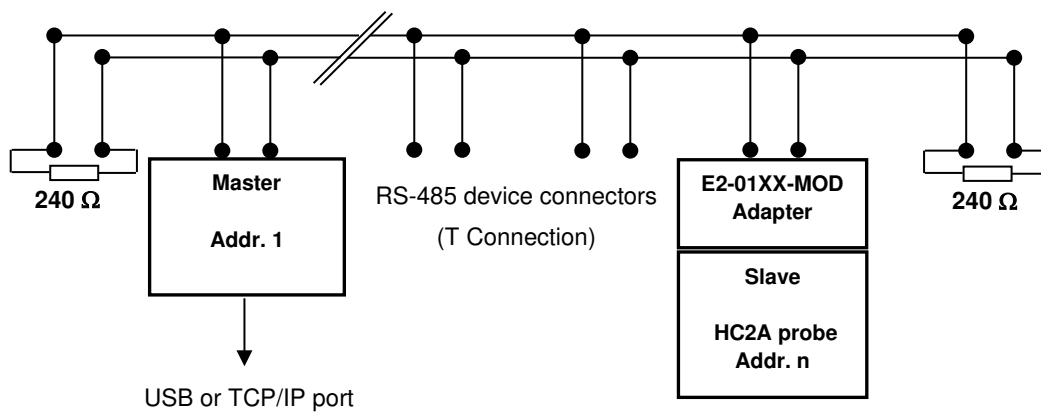

Note:

- The master device can be either a transmitter such as the HF5 (USB or TCP/IP interface) or an adapter such as the AC3010 cable (USB)
- Power to the combination E2-01XX-MOD and HC2A probe can be provided by an individual AC adapter or by a central voltage source connected to the RS-485 network (requires cables with 2 twisted pairs: one for the data, the other for power)

HygroClip2 ADVANCED	rotronic
E-M-HC2A-V1_7.docx	Manual

Analog connection example:

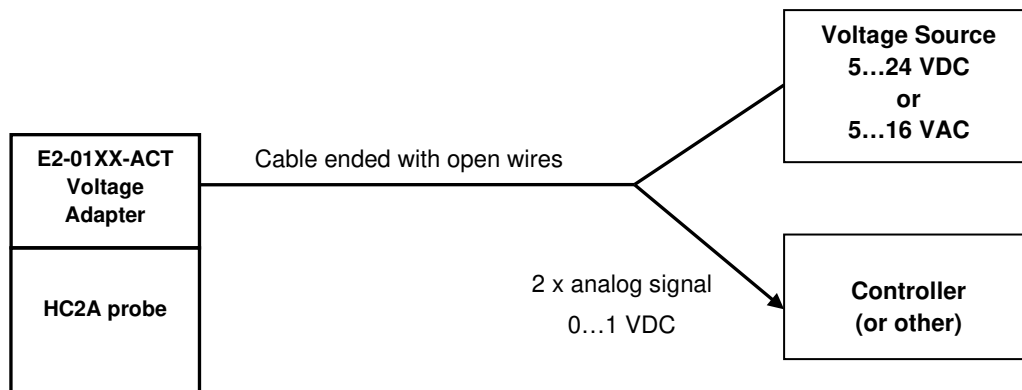

7.3 Hand-held probes used with an indicator

The most common source of error when measuring relative humidity with a hand-held probe is a difference between the temperature of the probe and the temperature of the environment. At a humidity condition of 50 %RH, a temperature difference of 1°C (1.8 °F) typically results in an error of 3 %RH on relative humidity.

When using a humidity probe with a portable indicator, it is good practice to monitor the display for temperature stability. When moving the probe from one area to another, the probe should be given sufficient time to equilibrate with the environment to be measured. This time can be shortened, and errors avoided, by using the probe configuration that fits best for your application.

In extreme situations, condensation may occur on the sensors when the probe is colder than the environment. As long as the humidity / temperature limits of the humidity sensor are not exceeded, condensation does not alter the calibration of the sensor. However, the sensor has to dry out before it can provide a valid measurement.

Non-moving air is an excellent insulator. When there is no air movement, surprising differences in temperature and humidity can be noted over short distances. Air movement at the probe generally results in measurements that are both faster and more accurate.

HygroClip2 ADVANCED	rotronic
E-M-HC2A-V1_7.docx	Manual

8 Maintenance

8.1 *Cleaning or replacing the dust filter*

Depending on the conditions of measurement, the filter should be checked from time to time. Corroded, discolored or clogged filters should be replaced.

8.2 *Periodic calibration check*

Both the Pt 100 RTD temperature sensor and associated electronics are very stable and should not require any calibration after the initial factory adjustment.

Long term stability of the ROTRONIC HYGROMER® humidity sensor is typically better than 1 %RH per year. For maximum accuracy, calibration of the probe should be verified every 6 to 12 months. Applications where the probe is exposed to contaminants may require more frequent verifications. Calibration and adjustment of the HC2A probe can be done with either a PC with the HW4 software installed or with the HP23 hand-held calibrator. For connecting the HC2A probe to a PC, use a digital adapter cable AC3001 (see document **E-M-HC2-accessories**).

Procedure for adjusting the HC2A probe with the ROTRONIC HW4 / HW5 software:

- Start HW4 / HW5 software on the PC and search for the HC2A probe.
- After finding the HC2A probe with HW4, expand the device tree to see the HC2A probe functions and select **Probe Adjustment**.
- For further instructions see HW4 manual **E-M-HW4v3-A2-001** or Online manual HW5: [Online manual HW5](#)

8.3 *Validation of the output signals transmission*

If so desired, transmission of the HC2A probe output signals can be validated by using the probe simulator function. The HW4 software is required to enable and configure this function. When the function is enabled the probe generates digital and analog signals corresponding to values specified by the user.

HygroClip2 ADVANCED	rotronic
E-M-HC2A-V1_7.docx	Manual

9 Firmware updates

Firmware updates will be available on the ROTRONIC website for downloading. For connecting the HC2A probe to a PC, use a digital adapter cable AC3001 (see document **E-M-HC2-accessories**).

Procedure for updating the firmware:

- o Connect the HC2A probe to the HW4 PC as explained in the HW4 manual **E-M-HW4v3-Main**
- o Copy the firmware update file from the ROTRONIC website to the PC.
- o Start HW4 software on the PC and search for the HC2A probe.
- o After finding the HC2A probe, expand the device tree to see the HC2A probe functions. Select Device Manager. In the Device Manager menu bar select Tools > Firmware Update. For instructions see document **E-M-HW4v3-F2-001**.

HygroClip2 ADVANCED	rotronic
E-M-HC2A-V1_7.docx	Manual

10 Technical data

General	
Device type	Humidity temperature probe
Mechanical configuration	See models
IP protection class	IP65

Power supply and connections	
Supply voltage (VDD)	3.3...5 VDC $\pm 0\%$
Nominal current consumption	<4.5 mA
Maximum start-up current unlimited	<50mA during 2 μ s
Minimum start-up current	8 mA during 2ms and 5 mA during 2s
Maximum current spike during operation	1 mA during maximum 2 μ s
Polarity protection	Mechanical only (keyed connector)

Humidity measurement	
Sensor	ROTRONIC HYGROMER [®] HT-1
Measuring range	0...100 %RH
Measurement accuracy	± 0.8 %RH, at 10...30 °C (HC2A-S(3), HC2A-IC, HC2A-IM, HC2A-IE) ± 0.5 %RH, at 10...30 °C / 10..90 %RH (HC2A-S(3)H)
Repeatability	0.3 %RH
Long term stability	<1 %RH / year
Sensor time constant	Typical 10 sec, 63% of a 35 to 80 %RH step change (1m/sec air flow at sensor)

Humidity measurement	
Sensor	ROTRONIC HYGROMER [®] HM1-SK
Measuring range	0...100 %RH
Measurement accuracy	± 0.8 %RH, at 10...30 °C (HC2A-S3A)
Repeatability	0.3 %RH
Long term stability	<1 %RH / year
Sensor time constant	Typical 10 sec, 63% of a 35 to 80 %RH step change (1m/sec air flow at sensor)

Temperature measurement

HygroClip2 ADVANCED	rotronic
E-M-HC2A-V1_7.docx	Manual

Sensor	Pt100 RTD, IEC 751 1/3 class B
Measuring range	-100...190 / 200 °C ⁶ (see also environmental limits)
Measurement accuracy	±0.1 °C, at 10...30 °C
Repeatability	0.05 °C
Long term stability	<0.1 °C / year
Sensor time constant	Typical 4 sec, 63 %RH of a step change (1 m/sec air flow at sensor)

Calculated parameters	
Psychrometric calculations	Dew or frost point (user configurable)

Start-up time and data refresh rate	
Start-up time	1.5 s (typical)
Data refresh rate	1.0 s (typical) – when not calculating any parameter

Configurable analog outputs	
Output 1	Can be made to correspond to any parameter
Factory default parameter	Relative humidity
Factory default scale	0...100 %RH
Output 2	Can be made to correspond to any parameter
Factory default parameter	Temperature
Factory default scale	-40...60 °C
Output 1 and Output 2	
Signal type	0...1 V
User configurable scaling limits	-999.99 ... 9999.99 engineering units
Offset at 0 V	+10 mV (maximum)
Ripple	<1.2 mV/x 2µs
Short circuit tolerant	Yes
Internal resistance	<10 Ω
Minimum external load	1000 Ω
Deviation from digital signal	<±1 mV from 0.002 to 1.0 V / + 2 mV from 0.0 to 0.002 V

Digital interface	
Interface type	UART (Universal Asynchronous Receiver Transmitter)
Organization	Dialog, duplex
Default configuration	Baud rate : 19200

⁶ The peak load at 200 °C is 100 h. See the sensor data sheet for detailed information on the pollution loads for the sensor.

HygroClip2 ADVANCED	rotronic
E-M-HC2A-V1_7.docx	Manual

	Parity : none Data bits : 8 Stop bits : 1 Flow Control : none
Tolerance	3 %
Baud rate configuration:	No
Logical levels	Logical 0: $\leq 0.3V * VDD$ Logical 1: $\geq 0.8V * VDD$
Maximum cable length	5 m (16.4 ft) w/o signal booster

General specifications	
Housing material	See Models
Collar material (connector)	Stainless steel, DIN 1.4301
Dust filter material	See Models
Physical dimensions	See Models
Weight	See Models

Conformity to standards	
CE / EMC immunity	EMC Directive: 20.04.2016: 2014/30/EU EN 61000-6-1: 2007, EN 61000-6-2: 2005 EN 61000-6-3: 2007+A1:2011+AC:2012, EN 61000-6-4: 2007+A1:2011 Performance criterion: www.rotronic.com
Solder type	Lead free (RoHS directive 2011/65/EU)
FDA / GAMP directives	compatible

Environmental limits	
Storage and transit	-50...+100 °C / 0...100 %RH, non condensing
Operating limits at electronics	-50 ... +100 °C 0...100 %RH, non condensing
Temperature limits at sensor	See Models
Maximum humidity at sensor	The sensor withstands 90 °Cdp. This results in the following conditions: 100 %RH up to 90 °C (194 °F) 78 %RH at 96 °C (204.8 °F) 34 %RH at 120 °C (248 °F) 17 %RH at 142 °C (287.6 °F) The sensor HM1-SK only withstands 60 °Cdp
Maximum air velocity at probe	50 m/s (3,28 ft /s), according to filter specifications

HygroClip2 ADVANCED	rotronic
E-M-HC2A-V1_7.docx	Manual

Critical environments	See HT-1 data sheet
-----------------------	---------------------

11 Accessories and parts

For accessories and parts such as the HW4 configuration software, extension cables, adapter cables, calibration accessories and spare dust filters, please see document **E-M-HC2-accessories**.

12 Supporting documents

Document File Name	Contents
E-M-HC2-accessories	Accessories and parts for probes, indicators and transmitters
E-T-AC3000-DF-V1	AirChip3000 Description and Main Functions
E-M-HW4v3-DIR	List of the HW4 manuals
E-M-HW4v3-Main	HW4 software version 3: General instructions and functions common to all devices
E-M-HW4v3-F2-001	HW4 software version 3: HC2A probe series Device configuration and AirChip3000 functions
E-M-HW4v3-A2-001	HW4 software version 3: Probe Adjustment function AirChip3000 devices
E-M-HW4v3-DR-001	HW4 software version 3: Data Recording Function AirChip3000 Devices
E-M-AC3000-CP	AirChip3000 Communication Protocol
E-M-CalBasics	Temperature and humidity adjustment basics Instructions for using the ROTRONIC humidity standards
E-T-HumiDefs	Humidity Definitions
Online Manual HW5	HW5-Software-Manual: HC2A probes software functions, device configuration

HygroClip2 ADVANCED	rotronic
E-M-HC2A-V1_7.docx	Manual

13 Document releases

Doc. Release	Date	Notes
V1_0	August 2016	Original release
V1_1	November 2016	Waterproof is specified more in detail, page 22 Max. wind speed adapted (technical specifications)
V1_2	April 2017	Technical drawings HC2A-SM Filter and support specifications edited Offset analogue output +10mV
V1_3	April 2017	Legend adapted
V1_4	July 2018	HC2A-IC402/405/502/505/702/705 removed from manual
V1_5	July 2019	HC2A-IM102-M/302-M/305-M added HC2A-IC402-A/IC702-A added Section Filters reworked
V1_6	October 2020	HC2A-IE02-G/IE02-NPT added Section Filters reworked
V1_7	January 2022	HC2A-S3A added Section Filter reworked HW5 software added